

AIR TOOLS



 **SULLAIR®**

BEFORE YOU INVEST IN AIR TOOLS, CONSIDER THE COMPANY BEHIND THEM.

WITH SULLAIR, YOU'RE NOT JUST BUYING AIR TOOLS. YOU'RE BUYING DECADES OF EXPERTISE IN THE PRODUCTION OF AIR TOOLS.

Sullair's reputation as a leading air tool manufacturer is based on more than a half century of experience and expertise in air tools production. To capitalize on these exceptional resources of skill and technology, Sullair built its state-of-the-art facility in Montbrison, France, devoted to the manufacture of Sullair air tools. In this plant, which features the most advanced equipment and the most advanced production techniques, Sullair air tools are manufactured to the highest quality standards in ISO 9001 quality systems.

You're buying from a market leader.

Sullair tools are known around the world for their innovative design, quality construction and extremely dependable performance. Sullair paving breakers, ergonomically designed for greater operator comfort and reduced fatigue, are at work in every corner of the globe. Sullair rock drills, built for durability and trouble-free performance, are raising productivity at job sites everywhere. Rugged Sullair chipping hammers are performing with complete dependability on demanding projects worldwide. At construction sites, in mines and quarries, on bridges and roads the world over—wherever quality and performance are called for, Sullair is the tool of choice.

You're buying global capabilities.

Sullair is constantly exploring new ways to produce higher performance, more energy efficient compressed air equipment for its customers worldwide. Through a

broad international network of field sales and service offices and authorized distributors, Sullair serves the compressed air needs of the construction and mining industries in every area of the world.



Sullair's manufacturing facility in Montbrison, France, is devoted to the production of Sullair air tools.

You're buying customer service.

Sullair's after-market support network provides knowledgeable customer service, including on-site troubleshooting and technical assistance, worldwide availability of Sullair replacement parts and timely, dependable product delivery. At Sullair, Total Customer Satisfaction is a cornerstone of corporate philosophy.



Sullair tools await inspection and testing prior to shipment to customers around the world.

You're buying breadth of product.

Sullair's complete line of air tools includes paving breakers, chipping hammers, rock drills, utility drills, demolition tools, tampers, clay diggers, air hoses and accessories. Employing the innovative concept

of "power through simplicity," Sullair engineers have designed these tools with fewer high-wear parts and reduced air consumption requirements. Sullair tools also offer the advantages of outstanding operator comfort, low maintenance and quiet operation.

Instantly recognizable by their quality plated finish, Sullair tools are durable, easy to clean and easy to spot on busy job sites. Built for hard use and long trouble-free life, Sullair tools are warranted for up to two years against defects and wear.

To complement and power the tools, Sullair offers a complete range of air compressors. Sullair air compressors are compact yet totally accessible internally, with the outstanding features and reliable performance you've come to expect of Sullair.

You're buying commitment to innovation and quality.

ISO 9001 certification has been earned by the company's North American and European manufacturing facilities. Sullair takes pride in its dedication to excellence and its commitment to innovation. At Sullair, we are always striving to expand our expertise, so that we may better serve our customers' needs.



Utilizing its exceptional resources of skill and technology, Sullair produces air tools of outstanding quality.



WE HAVE THE RIGHT TOOL FOR YOUR JOB. SULLAIR TOOL APPLICATION GUIDE.

APPLICATIONS	TOOL	SULLAIR MODEL	CLASS	WEIGHT	CFM
<ul style="list-style-type: none"> • Light chipping • Overhead fine detail and restoration work 	Light Chipping Hammer	MLC-10	10#	12 lbs.	18
<ul style="list-style-type: none"> • Horizontal and overhead applications • Also industrial applications 	Chipping Hammer	MCH-2/3/4	15#	16-19 lbs.	26-33
<ul style="list-style-type: none"> • Cutting and driving large rivets • Heavy duty demolition work 	Rivet Buster	MRB-8/11	30#	30-33 lbs.	44-50
<ul style="list-style-type: none"> • Breaking light concrete and other light jobs 	Light Paving Breaker	MPB-30A	30#	35.5 lbs.	37
<ul style="list-style-type: none"> • Concrete bridge decks and general demo work 	Light Paving Breaker	MPB-35A	40#	39 lbs.	49
<ul style="list-style-type: none"> • Concrete road breaking and other general demo work 	Medium Paving Breaker	MPB-60A	60#	69.5 lbs.	48
<ul style="list-style-type: none"> • Heavy demo work breaking tough, reinforced concrete 	Heavy Paving Breaker	MPB-90A	90#	92 lbs.	62
<ul style="list-style-type: none"> • Excavation of clay and hardpan • Light horizontal demolition work 	Light Demolition Tool	MDT-22	20#	24.7 lbs.	33.4
<ul style="list-style-type: none"> • Medium demolition work 	Medium Demolition Tool	MDT-30	30#	33 lbs.	37
<ul style="list-style-type: none"> • Excavation of clay and hardpan • Light horizontal demolition work 	Medium Digger	MCD-30	30#	33.8 lbs.	37
<ul style="list-style-type: none"> • Compacting backfill in ditches, trenches, foundations and around poles 	Backfill Tamper	MBT-6	35#	40.5 lbs.	32
<ul style="list-style-type: none"> • Setting anchors • Drilling holes in concrete and bricks 	Hammer Drill	MRD-9	9#	9 lbs.	21
<ul style="list-style-type: none"> • Setting anchors • Drilling holes in concrete and bricks 	Light Rock Drill	MRD-30	30#	34 lbs.	53
<ul style="list-style-type: none"> • Drill for depths up to 6 feet and 1-1/2" diameter 	Light Rock Drill	MRD-40	40#	45.5 lbs.	80
<ul style="list-style-type: none"> • Drill for depths up to 10 feet and 1-3/4" diameter 	Medium Rock Drill	MRD-50	50#	48.5 lbs.	123
<ul style="list-style-type: none"> • Drill for depths up to 20 feet and 2" diameter 	Heavy Rock Drill	MRD-55	55#	56 lbs.	95
<ul style="list-style-type: none"> • Drill for depths up to 25 feet and 3" diameter 	Heavy Rock Drill	MRD-60	60#	59 lbs.	98

SULLAIR PAVING BREAKERS ARE DESIGNED TO

FEWER WEARING PARTS, LESS MAINTENANCE, GREATER OPERATOR COMFORT, LESS FATIGUE, LESS AIR CONSUMPTION

THE SULLAIR PAVING BREAKERS ARE DESIGNED FOR WORK EFFICIENCY AND A LONG, TROUBLE-FREE LIFE.

High-Wear Parts Reduced

The Sullair breakers have eliminated most high-wear parts. Fewer parts mean less wear, less maintenance, and less downtime.

No Tappet System

Unlike conventional breakers, Sullair breakers have no multi-part tappet system. With fewer parts, wear is reduced and risk of air leaks is minimized. With no tappet system, which requires three independent impacts, noise is also reduced.

One Piece, Non-Protrusive Housing

A leakproof air cushion forms at the end of the piston stroke and stops the piston from direct impact when the tool is not breaking. The elimination of side rods, nuts and springs makes Sullair breakers sleeker and more comfortable to operate.

Minimal Lubrication Required

With only two parts moving during operation, normal oil carry-over from the compressor, combined with moisture in the air, will usually provide sufficient lubrication under normal operating conditions. Manual lubrication before storage is sufficient.

Direct Impact Piston

One moving impact part minimizes maintenance.

Parts Interchangeability

Standardization of design permits a high degree of interchangeability of parts between Sullair models.

Quieter

The piston, impacting directly on the steel shank rather than a tappet, reduces noise level of the breaker.

Super-Silenced/Anti-freeze Option

A unique silencer reduces noise levels by 6 dBA, while preventing the tool from freezing, even in the coldest climates.

Anti-Vibration Option

The flex handle option reduces up to 60% of the vibration to the operator without a loss of power.

Smoother Operation

Reduced kickback is less fatiguing to the operator.

Improved Latch Design

Durable double roll pin permits easy steel changing.

Less Air Consumption

The direct impact piston design, non-corrosive distribution valve and one-piece housing dramatically reduce air consumption. You can operate more tools from a single compressor. For example, a 125 cfm compressor will operate two MPB 90 breakers.

Two-Year Limited Warranty

All Sullair breaker parts are warranted for two years against manufacturing defects. Additionally, should a part wear out during normal operation, it is covered by Sullair's exclusive two-year warranty.

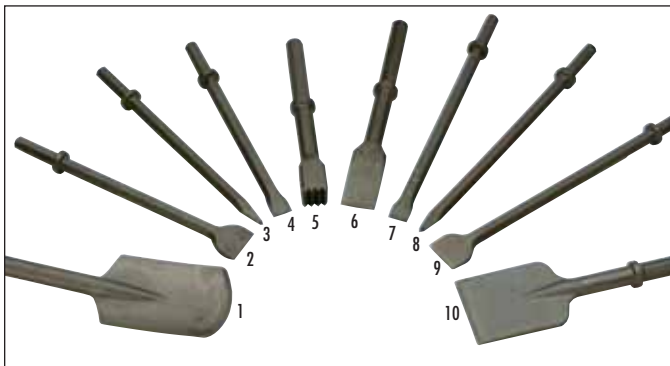

Paving Breaker Steels are available in 14" to 18" lengths, 7/8" X 3 1/4" to 1 1/4" X 6" shank size. Sullair's selection includes: (1) Clay Spades, (2 and 9) Wide Chisels, (3 and 8) Moil Points, (4 and 7) Narrow Chisels, (5) Bushing Tools, (6) Brick Wedges, and (10) Asphalt Cutters.

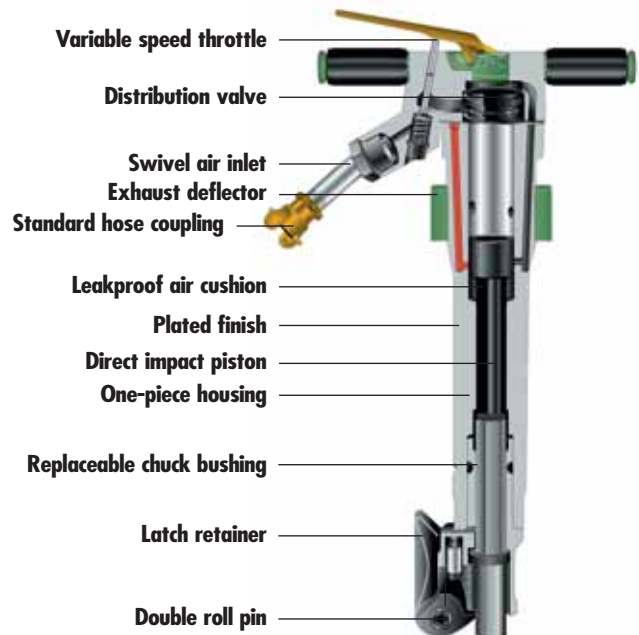

TO WORK BETTER AND LAST LONGER.

PAVING BREAKER DESIGN SPECIFICATIONS

Model	Weight lbs.	Length in.	Bore and Stroke in.	Blows/Minute	Air Consumption cfm	Air Inlet NPT	Shipping Weight lbs.	Chuck Size
MPB-90A	92	27½"	2⅞" x 5⅝"	1380	62 cfm	¾"	97	1⅛" HX x 6" 1¼" HX x 6"
MPB-60A	69½	26½"	2⅝" x 5⅝"	1360	48 cfm	¾"	74	1⅛" HX x 6" 1¼" HX x 6"
MPB-35C	39	25½"	1¾" x 5⅞"	1200	49 cfm	⅝"	43	1" HX x 4¼"
MPB-30A	35½	23"	1⅝" x 3⅝"	1850	37 cfm	⅝"	41	⅞" HX x 3¼" 1" HX x 4¼"
MPB-90AF	99½	28⅞"	2⅞" x 5⅝"	1380	62 cfm	¾"	105	1⅛" HX x 6" 1¼" HX x 6"
MPB-60AF	77	28⅞"	2⅝" x 5⅝"	1360	48 cfm	¾"	82	1⅛" HX x 6" 1¼" HX x 6"
MPB-90AS	94	27⅞"	2⅞" x 5⅝"	1380	62 cfm	¾"	101	1⅛" HX x 6" 1¼" HX x 6"
MPB-60AS	71½	26¾"	2⅝" x 5⅝"	1360	48 cfm	¾"	79	1⅛" HX x 6" 1¼" HX x 6"
MPB-90AFS	101	28⅞"	2⅞" x 5⅝"	1380	62 cfm	¾"	108	1⅛" HX x 6" 1¼" HX x 6"
MPB-60AFS	78½	28¼"	2⅝" x 5⅝"	1360	48 cfm	¾"	86	1⅛" HX x 6" 1¼" HX x 6"
MCD-30	33¾	24"	1⅝" x 3⅝"	1850	37 cfm	⅝"	39	⅞" HX x 3¼" 1" HX x 4¼"

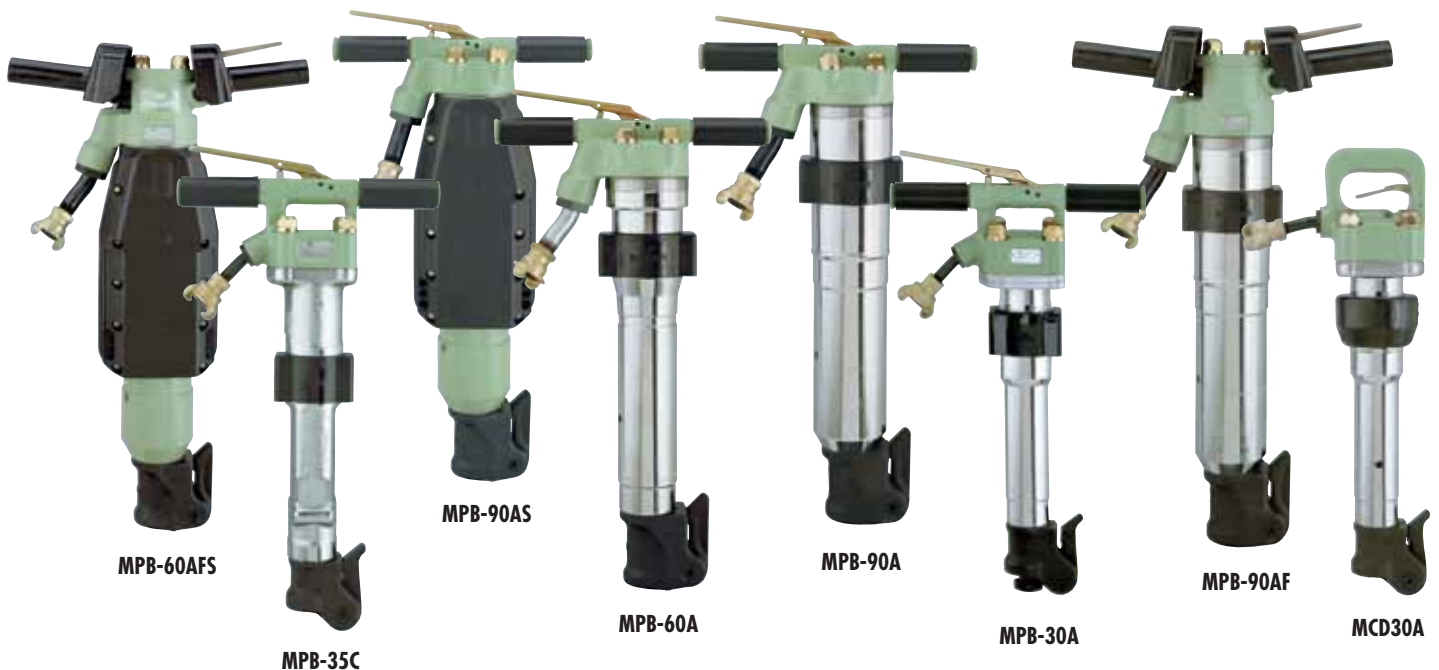

ANTI-VIBRATION PAVING BREAKER

ERGONOMICALLY DESIGNED, FEATURES A HINGED ANTI-VIBRATION HANDLE THAT REDUCES UP TO 60% OF VIBRATIONS TO THE OPERATOR WITHOUT LOSS OF POWER. BY ABSORBING THE SHOCK, THE ANTI-VIBRATION HANDLE REDUCES OPERATOR FATIGUE, LESSENS STRESS TO THE UPPER BACK AND SHOULDERS, AND ULTIMATELY PROMOTES PRODUCTIVITY.

Researching Breaker Vibration

This handle design is based on research conducted by Sullair's French operating unit, in association with the French government's INRS (equivalent to U.S.A.'s OSHA). Evaluating the stresses of paving breakers then in existence, the team found that the vibrations (often identified as kickback) came from pressure forces which act on both the body and the hitting piston of the machine. Research showed that breaker vibrations—at a rate of 1000 to 1500 per minute—are relayed through muscular contraction of the hands and arms to the rest of the body.

Finding the Ideal Solution

Over a period of years, the team investigated various approaches to reducing the effects of breaker vibration. Several prototypes were built and tested as the effort focused on developing a sturdier handle while providing simple and progressive start-up. The research culminated in the design of the Anti-Vibration Paving Breaker.

A Hinged Handle and Isolators

In this tool, vibrations are reduced by crossed handles that swivel on two pins on either side of the breaker head. The design provides sufficient clearance while keeping the handles compact. Two helical springs prevent direct contact between the handles and the body of the breaker. The tension of the springs not only provides sufficient thrust when the breaker is operating; it also allows the springs to act as efficient isolators.

Other Design Improvements

The new handle design led to other design improvements. For example, in order to hinge the handles correctly, the breaker's head—particularly the compressed air inlet—had to be completely redesigned.

Power Through Simplicity

The handle suspension system is independent and has no effect on the breaker's striking power. Based on a "power through simplicity" concept, the striking system uses a single piston that is guided through the entire length of the stroke.

No Tappet System

Unlike conventional breakers, Sullair breakers have no multi-part tappet system. With fewer parts, wear is reduced and risk of air leaks is minimized. With no tappet system, which requires three independent impacts, noise is also reduced.

High Impact Energy

Tests prove that these single piston breakers deliver more impact energy, pound for pound, than conventional breakers. The heavier long stroke also reduces piston speed, thus extending the life of the tool.

Less Air Needed

The breaker's direct impact piston design, non-corrosive distribution valve and one-piece housing dramatically reduce air consumption. As a result, more Anti-Vibration Paving Breakers can be operated from a single compressor.



Anti-Vibration Handles

SULLAIR RIVET BUSTERS

POWER FOR CUTTING OFF LARGE RIVET HEADS, HEAVY-DUTY CHIPPING, AND CONCRETE BREAKING. APPLICATIONS INCLUDE BRIDGE JOBS, STEEL STRUCTURE MAINTENANCE, RAILROAD CAR REPAIR, SHIPYARDS, PETROCHEMICAL PLANTS AND DEMOLITION WORK.

D-Handle with Inside Trigger
Handle design provides comfort and control to the operator in demolition applications.

Variable Throttle Control
Allows variable speed control for maximum production.

Muffler and Screened Inlet Bushing Standard
Provides quieter operation and filters the inlet from contaminating particles.

Interchangeable Parts Provide Flexibility
Interchangeable parts (except cylinder) reduce inventory and increase parts versatility.

Simplified Control Valve
Allows for smoother operation in dirty conditions through precisely engineered tolerances.

90-Day Parts Warranty
This Sullair warranty covers all tool parts against manufacturing defects.

Lubrication
Rivet Busters require inline lubrication (option).



For use on concrete, Sullair offers Chisel and Mail Point Steels for its Rivet Busters. 11X Jumbo is standard.

MRB-8 & MRB-11 RIVET BUSTER DESIGN SPECIFICATIONS

Model	MRB-8	MRB-11
Net Weight	30 lbs.	33 lbs.
Length	22½"	25½"
Shipping Weight	35 lbs.	38 lbs.
Bore and Stroke	1¾" X 8"	1¾" X 11"
Blows per Minute	1140	850
Air Consumption	44 cfm	50 cfm
Air Inlet	½" NPT	½" NPT
Chuck Size	11X Jumbo	11X Jumbo



MRB-8

MRB-11

SULLAIR CHIPPING HAMMERS ARE DESIGNED

THE SULLAIR CHIPPING HAMMER IS DESIGNED FOR RUGGED DEPENDABILITY. CHECK THESE FEATURES.

Four Bolt Backhead

This unique design reduces handle breakage. The common problem of a threaded handle-to-barrel connection coming loose and damaging the handle and internal parts has been eliminated.

D-Handle

The strong "D" configuration is large enough to allow a comfortable, sure grip, even for a gloved hand.

Minimal Lubrication Required

Because of the Sullair chipping hammer's unique design and materials, normal oil carry-over from the compressor, combined with moisture in the air, will usually provide sufficient lubrication under normal operating conditions.

Smoother Operation

The Sullair chipping hammer's unique backhead design results in greater operator comfort.

Choice of Stroke Length and Bushings

The Sullair chipping hammer is available in 2", 3" and 4" strokes with either .680 round or .580 hex bushings.

Choice of Retainers

Oval collar retainers are included as standard. Optional retainers available are universal ball type and round collar.

Rotatable Exhaust Deflector

A durable molded exhaust deflector directs exhaust air away from the operator.

Air Inlet Option

Two air inlet bushings are furnished: 3/8" NPT and 7/8-24, internal thread. The bushings provide for versatile hose connections while protecting the handle inlet threads. 8' whip hoses with fittings optional.

Limited Parts Warranty

Sullair provides a limited parts warranty of two years on the handle and cylinder, one year on all other parts except the retainer and retainer springs. In addition, should any other part wear out during normal operation, it is covered by Sullair's exclusive chipping hammer warranty.

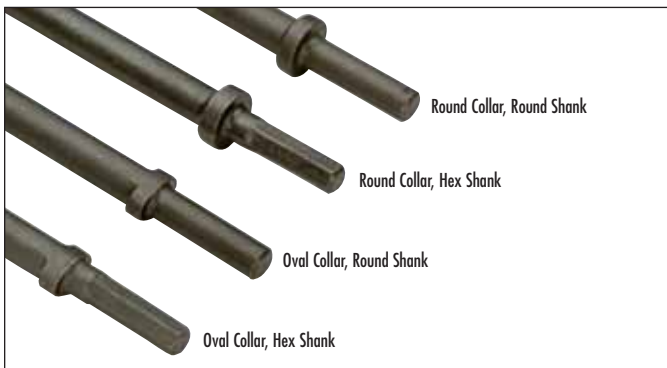

Collar and Shank Options for Sullair Chipping Hammer Steels allow you to choose the perfect fit for your project.

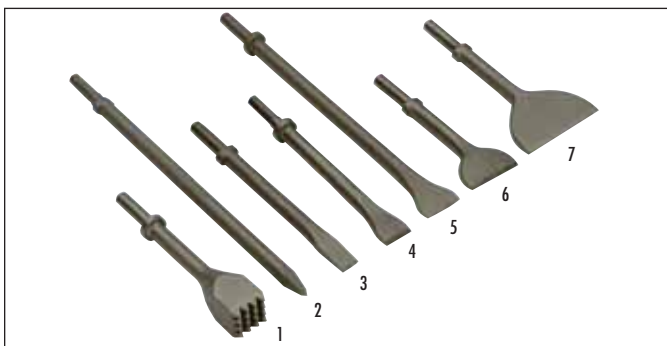

Chipping Hammer Steels include (1) Bushing Tools, (2) Moil Points, (3) Narrow Chisels, (4) 1 1/2" Wide Chisels, (5) 2" Wide Chisels. Consult factory for (6) 3" Wide Chisels, and (7) 5" Wide Chisels.

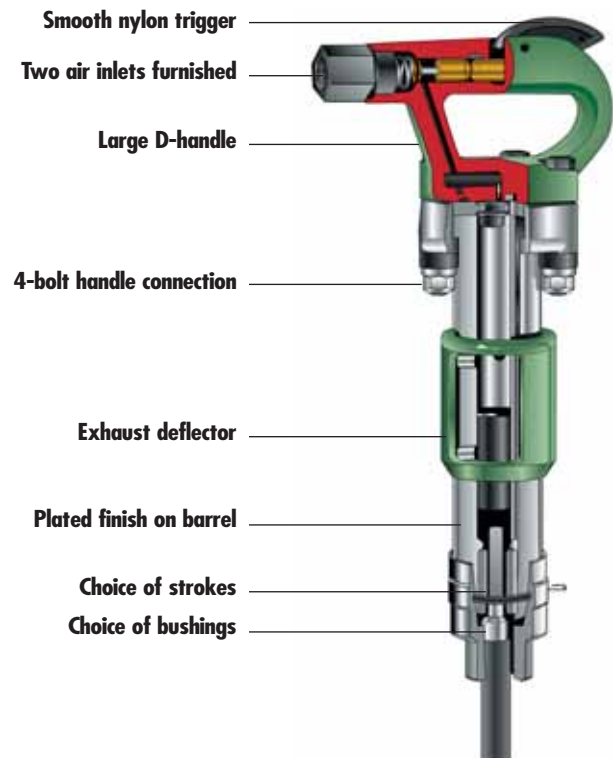

D AND BUILT TO LAST.

UTILITY HAMMER DESIGN SPECIFICATIONS

Model	Weight lbs.	Length in.	Bore & Stroke in.	Impact Rate blows/min.	Air Consumption cfm	Air Inlet Diameter in.	Shipping Weight lbs.	Chuck Size
MCH-2	16 $\frac{5}{8}$	14"	1 $\frac{1}{8}$ " x 3"	3600	34	$\frac{3}{8}$ " NPT or $\frac{7}{8}$ -24	18	.680 round .580 hex
MCH-3	17 $\frac{3}{4}$	15 $\frac{1}{4}$ "	1 $\frac{1}{8}$ " x 3 $\frac{3}{4}$ "	2280	33	$\frac{3}{8}$ " NPT or $\frac{7}{8}$ -24	19	.680 round .580 hex
MCH-3S	19 $\frac{3}{4}$	17"	1 $\frac{1}{8}$ " x 3 $\frac{3}{4}$ "	2280	33	$\frac{3}{8}$ " NPT or $\frac{7}{8}$ -24	20 $\frac{7}{8}$.680 round .580 hex
MCH-4	18 $\frac{5}{8}$	16 $\frac{1}{2}$ "	1 $\frac{1}{8}$ " x 4 $\frac{1}{4}$ "	1800	30	$\frac{3}{8}$ " NPT or $\frac{7}{8}$ -24	20	.680 round .580 hex
MCH-4S	20 $\frac{3}{4}$	18"	1 $\frac{1}{8}$ " x 4 $\frac{1}{4}$ "	1800	30	$\frac{3}{8}$ " NPT or $\frac{7}{8}$ -24	22 $\frac{1}{8}$.680 round .580 hex
MLC-10	12	14 $\frac{1}{2}$ "	1 $\frac{7}{64}$ " x 1 $\frac{13}{16}$ "	2940	17	$\frac{3}{8}$ " NPT or $\frac{7}{8}$ -24	14	.680 round .580 hex



SULLAIR DRILLS ARE DESIGNED FOR PERFORM

DEAD MAN HANDLE, VARIABLE DRILLING SPEEDS, ONE CONTROL FOR DRILLING AND BLOWING, FEWER PARTS FOR LESS MAINTENANCE

SULLAIR DRILLS ARE DESIGNED TO PROVIDE OPERATOR PROTECTION WHILE DELIVERING TROUBLE-FREE PERFORMANCE. CHECK THESE FEATURES.

Dead Man Safety Handle

The Sullair drills are designed so that the tool automatically stops operating when the operator releases the throttle lever.

One Control for Drilling and Blowing

The single throttle lever controls all tool functions from off, to blowing only, to progressive drilling speeds.

Variable Throttle Control

Allows stepless speed control for maximum drilling production.

Continuous Hole Cleaning

Blowing air is directed through the drill rod at all drilling speeds to clear debris from the hole.

Direct Rotation of the Piston

This feature reduces torque loss and eliminates wearing parts, such as the rifle bar assembly.

Less Maintenance

The unique design of the Sullair drills eliminates many high wear parts. This means less loss of power due to wear, less downtime to replace worn parts and lower overall maintenance costs.

Minimal Lubrication Required

With only two parts moving during operation, a non-corrosive distribution valve, less radial piston movement and high tech alloys, the Sullair drills do not require special rock drill oil. Normal oil carry-over from the compressor, combined with moisture in the air, will usually provide sufficient lubrication under normal operating conditions.

Oil Reservoir

A built-in oil reservoir assures direct lubrication to rotating parts. Use of standard 90-140 weight gear lubricant extends the life of critical parts.

One-Year Parts Warranty

This Sullair warranty covers all drill parts against manufacturing defects. In addition, should a part wear out under normal working conditions, it is covered by Sullair's exclusive one-year warranty.

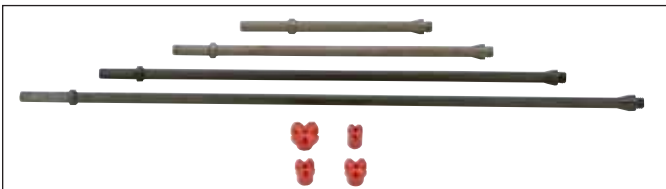

H-Thread Drill Steels are available in lengths from 12" to 48". H-Thread Carbide Tipped Rock Bits from Sullair are available in sizes from 1 1/2" to 3".



A wide variety of Carbide Tipped Drill Bits is available to compliment your Sullair Utility Drills and meet your project's needs. Round Shank Bit are available in sizes from 5/16" to 1 3/4"; Hex Shank from 1/2" to 1 1/4". Drilling depths from 8" to 18".



MRD-9 Chisels and Points are available in Round Shank only.

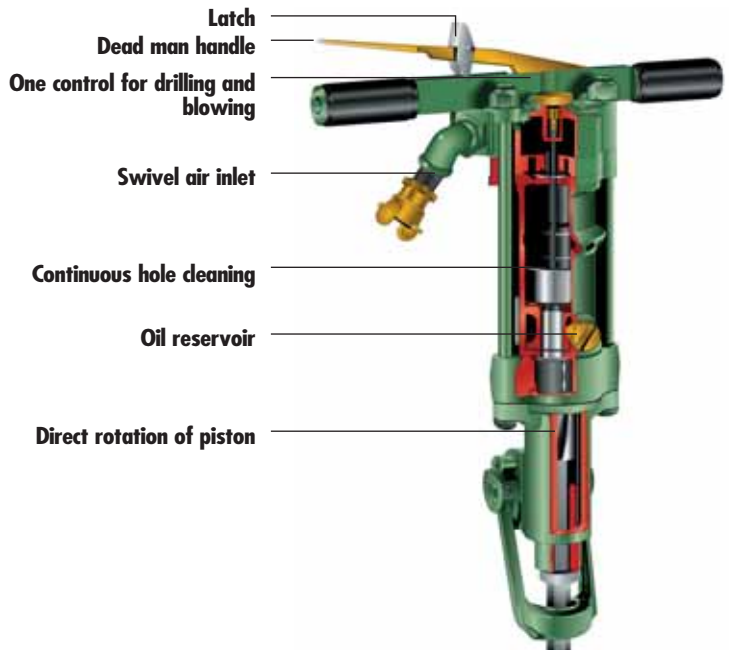

PERFORMANCE AND OPERATOR PROTECTION.

DRILLING HAMMER DESIGN SPECIFICATIONS

Model	Weight lbs.	Length in.	Bore and Stroke in.	Blows/Minute	Air Consumption cfm	Air Inlet NPT	Shipping Weight lbs.	Chuck Size
MRD-9	9	15½"	1 11/32" x 1 3/8"	2800	21	3/8"	10	3/4" RD x 3 3/4" 9/16" HX x 1 3/4"
MRD-30	34	21	2 5/32" x 1 3/4"	2300	53	3/4"	38	7/8" HX x 3 1/4" 7/8" HX x 4 1/4"
MRD-40	45½	23 1/8"	2 11/16" x 2 3/8"	1800	80	3/4"	52	7/8" HX x 3 1/4" 7/8" HX x 4 1/4" 1" HX x 4 1/4"
MRD-50	48½	23 1/4"	3 x 2 5/8"	1800	99	3/4"	55	7/8" HX x 3 1/4" 7/8" HX x 4 1/4" 1" HX x 4 1/4"

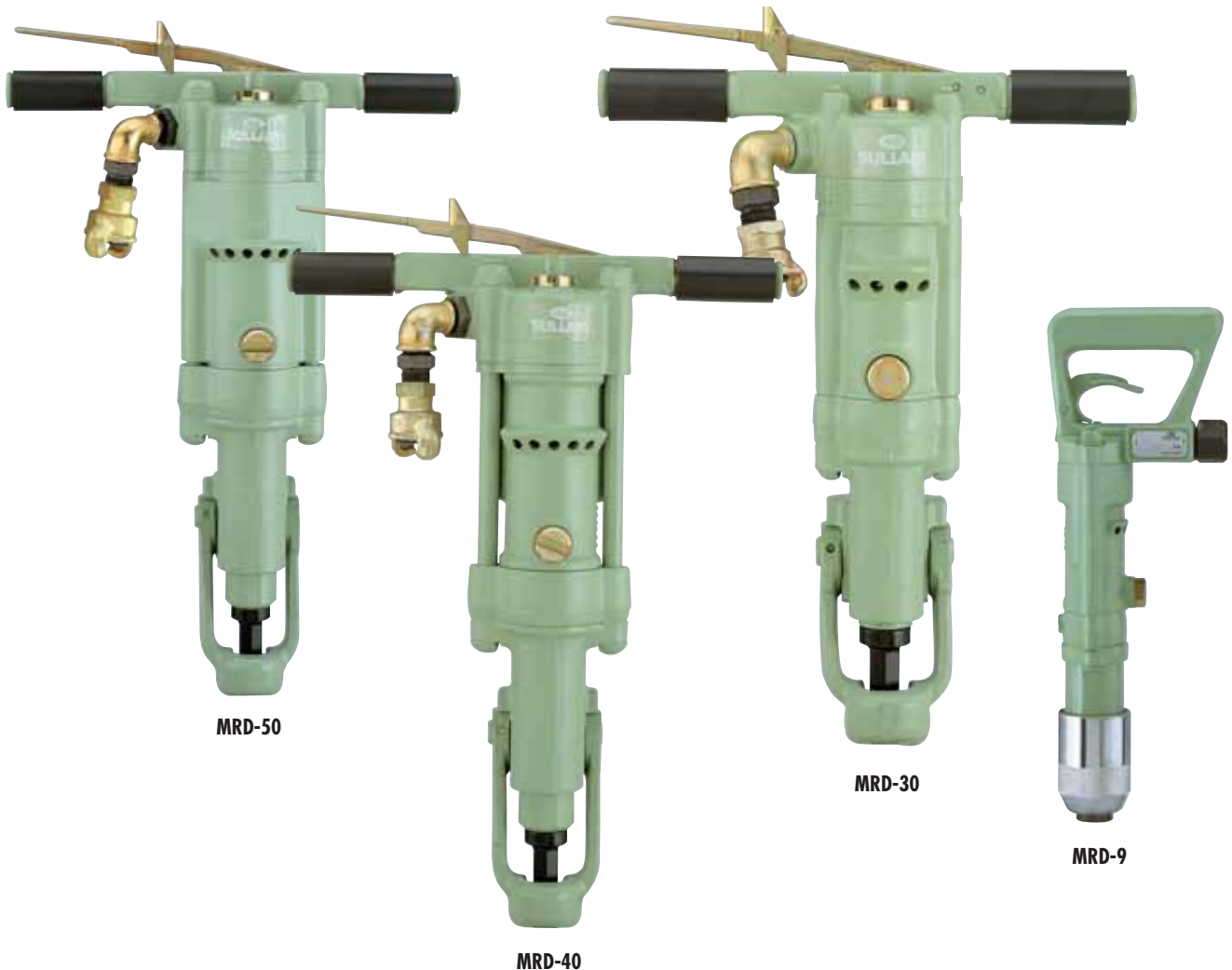

THE SULLAIR MRD-55 AND MRD-60 ROCK DRILLS

MRD-55 IS AN ALL-PURPOSE, HEAVY-DUTY, ROCK DRILL FOR HOLES UP TO 20 FEET DEEP IN THE HARDEST ROCK. FAST ROTATION FOR HIGH PRODUCTIVITY. SWIVEL AIR AND WATER INLET CONNECTION. MINIMAL PARTS CONVERT DRILL FROM DRY FOR GENERAL DRILLING TO WET FOR DUSTLESS DRILLING.

MRD-60 PROVIDES 200 RPM ROTATION AND A HEAVY DOWNFORCE OF 60 LBS FOR EASE OF PENETRATION IN HARD ROCK. SWIVEL AIR INLET CONNECTION, 2 DRILLING SPEEDS. EXHAUST VALVE TO CONTROL AIR BLOWING CONDITIONS, DRY BLOWING ONLY.

Rubber Handle Grips

Reduce vibration, lessening operator fatigue.

Controls for Drilling and Blowing

The MRD-55 has a single throttle lever to control all tool functions from off, to blowing only, to progressive drilling speeds. On the MRD-60, the throttle lever controls tool functions from off to two drilling speeds and the exhaust valve controls blowing velocity.

Adjustable Throttle Control on MRD-55

Allows variable speed control for maximum drilling production.

Continuous Hole Cleaning on MRD-55

Blowing air is directed through the drill rod at all drilling speeds to clear debris from the hole.

Reversible Rotation Pawls on MRD-55

Lengthens life for increased productivity.

Replaceable Chuck Bushing, Piston Cushion Bushing, and Rifle Nut

Ease of replacement extends tool life.

Front Exhaust on MRD-55

Cleaner operating conditions.

90-Day Parts Warranty

This Sullair warranty covers all tool parts against manufacturing defects.

MRD-55 Wet or Dry

Optional "Wet Kit" available for dustless drilling.

Internal oiler on MRD-60

Utilizes 90 wt. lube oil inline oiler to lubricate internal rifling and ratchet assembly.

MRD-55 and MRD-60

Constant feed inline oilers with 10 weight oil recommended for lubrication.

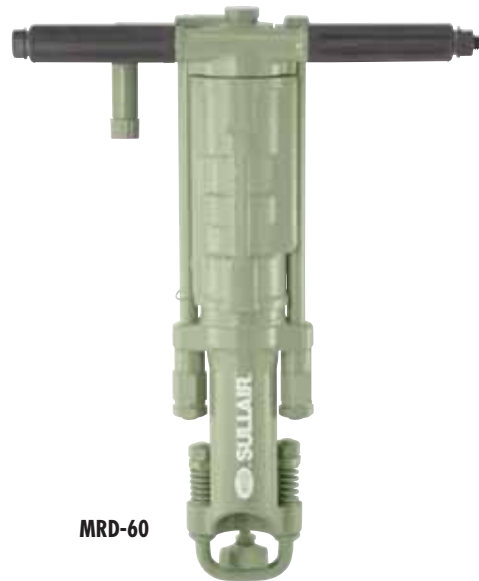

MRD-60



MRD-55

SPECIFICATIONS

Model	MRD-55	MRD-60
Net Weight	56 lbs.	60 lbs.
Length	23¾"	22"
Bore and Stroke	2⅝" x 2 ¹¹ / ₁₆ "	2⅝" x 2⅜"
Blows per Minute	1650	1800
Air Consumption	95 cfm	91 cfm
Air Inlet	¾" NPT	¾" NPT
Shipping Weight	60 lbs.	65 lbs
Chuck Size	1" HX x 4¼" ⅞" HX x 4¼"	⅞" HX x 4¼" 1" HX x 4¼"

THE SULLAIR BACKFILL TAMPER

THE SULLAIR MBT-6 BACKFILL TAMPER GIVES YOU ALL THE POWER FOR COMPACTING AT A SPEED WHICH ALLOWS COMFORTABLE CONTROL.

Applications

The Sullair MBT-6 backfill tamper is the ideal tool for compacting backfill around utility poles, foundations and other structures. It quickly and efficiently compacts backfill soil excavated to perform service line repair before patching the pavement.

Rotatable Exhaust Deflector

A durable molded exhaust deflector aims the exhaust away from the operator.

Standard Steel Butt

A 6" diameter solid steel butt is standard. Optional butts for special applications are available. The butt is held onto the piston rod with a hex head clamp screw for ease of assembly and removal.

Smooth Finish

Plated barrel promotes easy clean-off of backfill materials.

Minimal Lubrication Required

With the design features and premium materials of the MBT-6, normal oil carry-over from the compressor, combined with the moisture in the air, will supply sufficient lubrication under normal operating conditions.

No Packing Adjustment

There is no packing adjustment necessary for the Sullair MBT-6. The double seals retain their effectiveness for the life of the packing.

One-Year Limited Warranty

All tamper parts are warranted for one year against manufacturing defects. Additionally, should any part, excluding the butt and buttclamp screw, wear out during normal operation, it is covered by Sullair's exclusive warranty.



Backfill Tamper Butts, like all Sullair accessories, are made specifically for Sullair tools, so proper fit and performance are assured. Our selection includes: (1) 6" Malleable Iron, (2) 6" Steel Butt (standard), (3) 4" Aluminum Butt, (4) Pole Butt Half Moon and (5) 3" Aluminum Butt.

MBT-6 TAMPER SPECIFICATIONS

Net Weight	40½ lbs.
Length	48¾"
Shipping Weight	44 lbs.
Bore and Stroke	1½" X 5½"
Blows per Minute	500
Air Consumption	32 cfm
Air Inlet	¾" NPT or 7/8"-24 NPT
Butt Diameter	6"



MBT-6

SULLAIR MDT-22 & MDT-30 DEMOLITION TOOLS

Two Bolt Backhead

This unique design reduces handle breakage. The common problem of a threaded handle-to-barrel connection coming loose and damaging the handle and internal parts is therefore eliminated.

D-Handle

The strong "D" configuration is large enough to provide a comfortable, sure grip even for a gloved hand.

Minimal Lubrication Required

With its unique design and materials, normal oil carry-over from the compressor, combined with moisture in the air, will usually provide sufficient lubrication under normal operating conditions.

Smoother Operation

The Sullair demolition tool's unique design results in greater operator comfort.

Stroke Length

The piston has been sized relative to the length of the stroke to provide an improved weight/power ratio.

Air Inlet Option

Two air inlet bushings are furnished: 3/8" NPT and 7/8"-24, internal thread. The bushings provide for versatile hose connections while protecting the handle inlet threads.

Rotatable Exhaust Deflector

Directs exhaust air away from the operator and provides a comfortable grip. It also greatly decreases the sound level of the tool.



MDT-22 uses standard 7/8" X 3 1/4" shanks.

DEMOLITION TOOL SPECIFICATIONS

	MDT-22	MDT-30
Net Weight	24.7 lbs.	33 lbs.
Length	20"	24.5"
Shipping Weight	26 lbs.	35.6 lbs.
Bore and Stroke	1.5 X 4.5"	1.4 X 7.4"
Blows per Minute	1450	1000
Air Consumption	33.4	37.1
Air Inlet Diameter	3/8" NPT or 7/8"-24	3/8" NPT or 7/8"-24
Shank	7/8 hx X 3 1/4	11 X Jumbo
Retainer	Latch	Screw-on

MDT-22

The MDT-22 has quick change latch retainer and utilizes standard 7/8" X 3 1/4" hex steel. 2 year warranty



MDT-30

The MDT-30 has reliable screw-on retainer (no springs) and utilizes standard 11 x Jumbo rivet buster steel, sleeves and bumpers. 1 year warranty, excluding wear items, sleeves and bumpers.



MDT-30 uses 11X Jumbo steel.

SULLAIR NEEDLE SCALERS

Applications

The Sullair SANS needle scaler removes rust, scale, paint and weld splatter from irregular surfaces; and converts easily to a weld flux scaler. This versatile tool features an adjustable needle exposure and 19 steel needles (round pattern) as standard. Optional beryllium copper (non-sparking) needles are available.

Built-in durability

Sullair scalers are constructed of advanced materials for lighter weight and greater durability inside and out. Smooth, black oxide exterior allows easy clean-off of debris.

Lubrication

Due to the design tolerances of these tools, an in-line oiler should be used during operation.

90-day parts warranty

The Sullair warranty covers all scaler parts against manufacturing defects.

Front exhaust

This feature provides cleaner working conditions.

SULLAIR SCALER SPECIFICATIONS

	SANS	SCWF
Net Weight	6½ lbs.	4 lbs.
Length	17½"	9½"
Shipping Weight	8 lbs.	6 lbs.
Bore and Stroke	1" X 1⅛"	1" X 1⅛"
Blows/min.	4600	4600
Air Consumption	14 cfm	14 cfm
Air Inlet	⅜" FNPT	⅜" FNPT



Accessories include line oiler, hose and steels made specifically for Sullair needle scalers and weld flux scalers.

SULLAIR CONCRETE VIBRATORS

Applications

Concrete Vibrators are designed for low slump pours of concrete footings, slabs and walls. The correct diameter tool depends on wall thickness or concrete depth.

- Plated cylinders, easy to clean.
- Adjustable throttle for optimum performance.
- Only one moving part.
- Minimum on site lubrication.
- Standard hose length 10'.

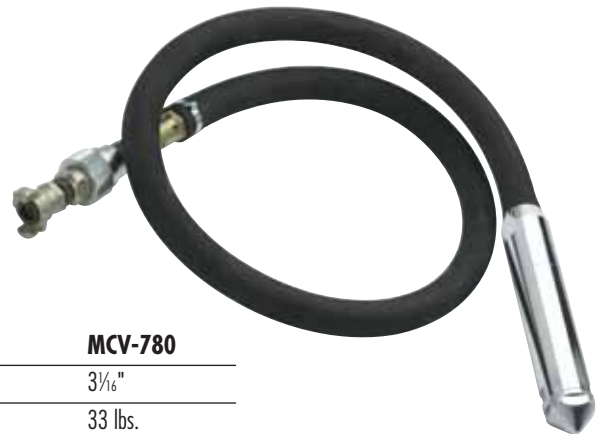

SULLAIR CONCRETE VIBRATOR SPECIFICATIONS

	MCV-300	MCV-400	MCV-580	MCV-780
Diameter	1⅜"	1½"	2¼"	3⅛"
Weight	5.3 lbs.	9 lbs.	18 lbs.	33 lbs.
Air Required	16 cfm @ 90 psi	17 cfm @ 90 psi	35 cfm @ 90 psi	51 cfm @ 90 psi
Hertz	18000	17000	16000	13000

SULLAIR SWING VALVE AND GENUINE ACCESSORIES

SULLAIR SWING VALVE COUPLINGS PROVIDE:

SAFE AND EASY AIR SHUT-OFF AT THE TOOL. NO NEED TO TURN OFF THE COMPRESSOR. SAFELY BLEEDS THE AIR FROM THE TOOL. SAVES TIME, SAVES MONEY

Easy Tool Changes

- Change the tool quickly
- Change the steels safely
- Prevents accidental firing of tool

Full Flow to Tool

- Full throat valve, no flow restriction
- Smooth bore no pressure loss in valve

Quick and Sure Connections

- Connect and disconnect under pressure
- No extra effort against line pressure
- Locking sleeve prevents accidental on/off
- When in "locked off" position, tool hose is vented. #1.
- Full flow when in "locked on" position. #2.

Complete 8' Whip Hose comes with One Optional Tool Connector:

- -7/8 X 24 male fine thread
- -1/2" MNPT male thread
- -3/8" MNPT male thread
- -2 lug universal coupling
- Entire whip is complete with swing valve and 2 lug connector

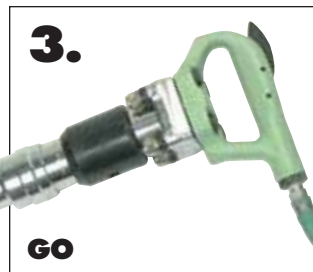

IF YOU'RE USING SULLAIR TOOLS, GET THE PERFORMANCE YOU PAID FOR. USE ONLY GENUINE SULLAIR ACCESSORIES.



www.sullair.com

SULLAIR CORPORATION, 3700 East Michigan Blvd., Michigan City, IN 46360 Telephone: 1-800-SULLAIR or 1-219-879-5451 Fax: 1-219-874-1214

SULLAIR EUROPE S.A., Zone des Granges, BP 82, 42602 Montbrison, Cedex, France, Telephone: (33) 4.77.96.84.70 Fax: (33) 4.77.96.84.99

SULLAIR ASIA LTD., 74 Joo Koon Circle, Jurong, Singapore 629093, Telephone: (65) 861-1211 Fax: (65) 861-2967 Telex RS25117

SHENZHEN SULLAIR ASIA INTERNATIONAL CO., LTD., Zuo Pao Tai Road, Chiwan, Shekou, Shenzhen 518068, China, Telephone: (86) 755-6851686 Fax: (86) 755-6853473

SULLAIR TAIWAN LTD., 2nd Fl. No. 96, Chien Kuo N. Road, Taipei 104, Taiwan, Telephone: 886-2-505-7256, Fax: 886-2-505-5480

SULLAIR ARGENTINA, Goncalves Dias 1145, 1276 Buenos Aires, Argentina, Telephone: 54-11-5941-4444, Fax: 54-11-5941-4549

SULLAIR AUSTRALIA, 11-15 Marlo Place, Hallam, VIC, Australia, Telephone: (613) 9703 8000, Fax: (613) 9703 8053