

### T-14D / T-16D / T-18D / T-20D

The Towmaster T-series large drop-deck trailer is designed for hauling mid-sized to large equipment. This model is built on a stout cold-formed I-beam tongue and main frame and features a 3-inch lip around the deck. The oak wood deck is supported by 3-inch I-beam crossmembers and Dexter® Torflex® rubber torsion axles provide a smooth tow. This trailer includes a bolt-on parking jack, LED lights, sealed wiring harness, spring-assist ramps, and a solid bar ramp hold-up.

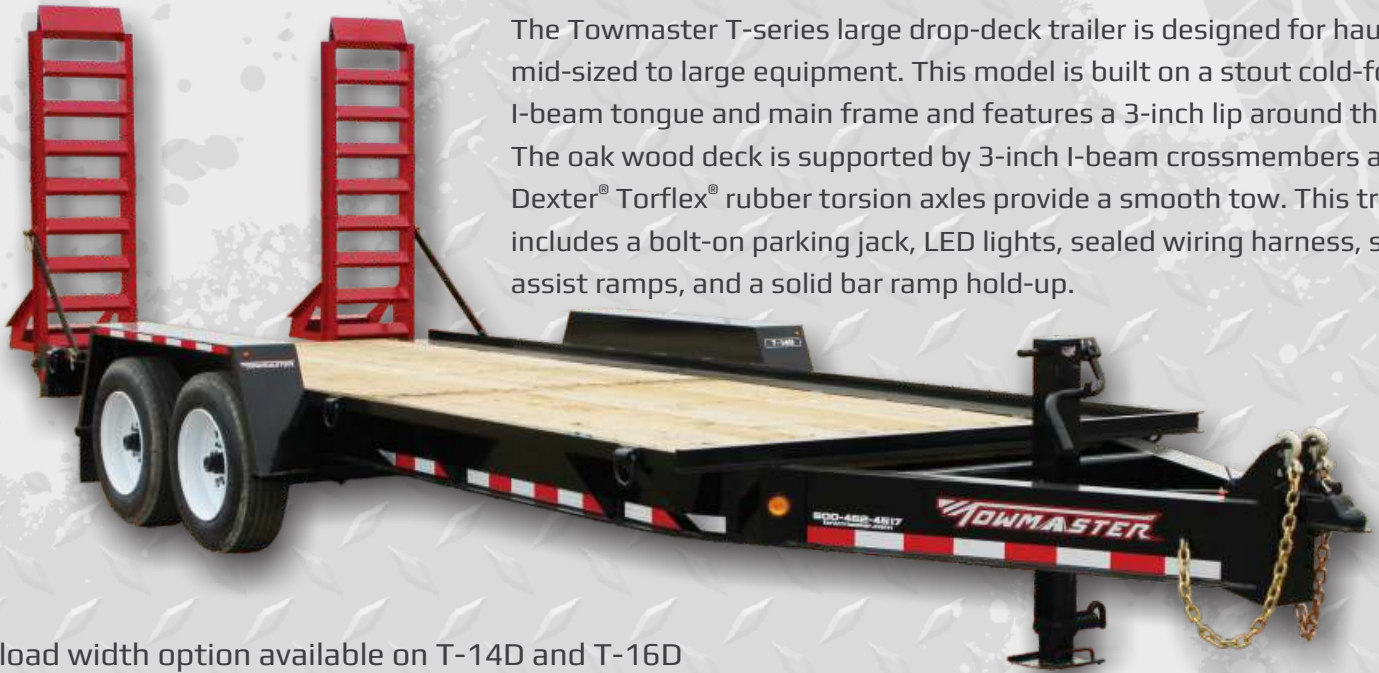

84" load width option available on T-14D and T-16D



Cold-formed one-piece I-beam tongue and main frame provide the strength you need to haul your equipment.



Spring-assist heavy-duty ramps are standard.



84" load width option on T-14D and T-16D includes an open-fender design.

#### Quick Specs:

- 2" nom. white oak wood deck
- 16', 18', or 20' deck
- One-piece formed fender/inner panel
- 23"-24" deck height (loaded)
- Dexter® Torflex® axles w/E-Z Lube
- Solid bar ramp hold-ups
- 82" between fenders (84" opt.)
- Electric brakes
- Grommet mounted LED lights



Photos may show optional equipment.

## AMERICA'S BEST BUILT TRAILERS FOR PROFESSIONAL HAULERS



800-462-4517  
TOWMASTER.COM



MORE MODELS • MORE OPTIONS • MORE CHOICES  
DROP-DECK • TILT BED • DECK-OVER • GOOSENECK • LOWBOY • HYDRAULIC TAIL

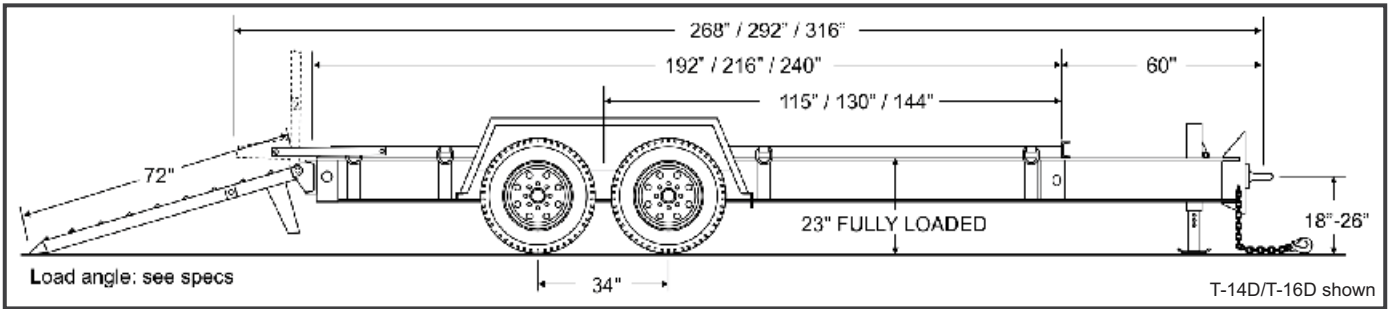

SPECIFICATIONS				
S=Standard O=Optional				
CAPACITY / DIMENSIONS	T-14D	T-16D	T-18D	T-20D
Approx. Payload (lbs/kg)	14,000 / 6350	16,000 / 7257	18,000 / 8165	20,000 / 9072
GVWR (lbs/kg)	18,200 / 8255	20,600 / 9344	22,600 / 10,251	24,600 / 11,158
GAWR (lbs/kg)	14,400 / 6531	16,000 / 7257	19,220 / 8718	20,000 / 9072
Approx. Avg. Weight (lbs/kg)	4,200 / 1905	4,600 / 2086	4,600 / 2086	4,600 / 2086
Overall Length – 16' (ft-in/mm)	22-4 / 6807	22-4 / 6807	22-4 / 6807	22-4 / 6807
Overall Length – 18' (ft-in/mm)	24-4 / 7417	24-4 / 7417	24-4 / 7417	24-4 / 7417
Overall Length – 20' (ft-in/mm)	26-4 / 8027	26-4 / 8027	26-4 / 8027	26-4 / 8027
Deck Height (loaded)(in/mm)	23 / 584	23 / 584	23.5 / 597	24 / 610
Overall Width (ft-in/mm)	8-6 / 2591	8-6 / 2591	8-6 / 2591	8-6 / 2591
Load Width (in/mm)	82 / 2083	82 / 2083	82 / 2083	82 / 2083
<b>TONGUE</b>				
Tongue Length 5'-0" (1524mm)	S	S	S	S
One-Piece Cold-Formed Tongue / Frame	S	S	S	S
Pintle Ring (in)	3	3	3	3
High-Tensile Safety Chain	3/8" Grade 70	3/8" Grade 70	3/8" Grade 70	3/8" Grade 70
Bolt-on Drop-Leg Parking Jack	12K	12K	12K	12K
<b>FRAME / RAMPS</b>				
Main Beam	High-Tensile W10 x 12	High-Tensile W10 x 17	High-Tensile W10 x 17	High-Tensile W10 x 17
Crossmembers	3" Jr I-beam	3" Jr I-beam	3" Jr I-beam	3" Jr I-beam
Headboard Height (in / mm)	4 / 102	4 / 102	4 / 102	4 / 102
Deck	2" nom. White Oak	2" nom. White Oak	2" nom. White Oak	2" nom. White Oak
Deck Lip (in / mm)	3 / 76	3 / 76	3 / 76	3 / 76
12 ga. One-piece formed fenders and inner panel	S	S	S	S
Ramps (Ladder Style) Length x Width (ft-in x in/mm)	6-0x18 / 1829x470	6-0x18 / 1829x470	6-0x18 / 1829x470	6-0x18 / 1829x470
Load Angle (degrees)	17	17	17	17
Ramp Spring-Assist	S	S	S	S
Ramp Hold-ups	Solid Bar	Solid Bar	Solid Bar	Solid Bar
Tie Downs	D-ring	D-ring	D-ring	D-ring
Number of Tie-Downs (Total / Side)	8 / 4	8 / 4	8 / 4	8 / 4
<b>SUSPENSION / TIRES</b>				
Rubber-Ride Axles w/Warranty	S	S	S	S
Axle Capacity (each) (lbs/kg)	7,200 / 3266	8,000 / 3629	10,000 / 4536	10,000 / 4536
Axle Spread (in/mm)	34 / 864	34 / 864	34 / 864	34 / 864
Hubs	E-Z Lube	E-Z Lube	Oil Bath	Oil Bath
Electric Brakes	S	S	S	S
Brake Size (in/mm)	12.25x2.5 / 311x64	12.25x3.38 / 311x86	12.25x3.38 / 311x86	12.25x3.38 / 311x86
Battery Break-Away Kit with Tow Charger	S	S	S	S
Wheels (in/mm)	17.5x6.75 / 445x171	17.5x6.75 / 445x171	17.5x6.75 / 445x171	17.5x6.75 / 445x171
Wheel Bolt Pattern	8-bolt	8-bolt	8-bolt	8-bolt
Tires / Load Range Rating	215/75R17.5 / H	215/75R17.5 / H	215/75R17.5 / H	235/75R17.5 / H

**STANDARD EQUIPMENT**

- Adjustable hitch height
- RV electrical plug
- Weather resistant sealed modular wiring
- Grommet mounted LED lights
- Registration holder
- Rust inhibiting primer
- Durable, rust inhibiting top coat
- Die-cut UV resistant vinyl decals
- D.O.T. approved conspicuity tape
- Mud flaps
- Adjustable ramp width spacing
- Trailer color: Equipment black
- Ramp color: Equipment red

**OPTIONAL EQUIPMENT**

- 2-5/16" ball coupler
- Gooseneck hitch
- 25K parking jack
- 6-pole round electrical plug
- 84" deck width (14D/16D-open fenders)
- Pallet fork holders
- 8K electric winch
- Additional tie-downs
- Pallet fork holders
- Paver side-load option (T-16D)
- 3 ft. beavertail (with 4 ft. ramps)
- Spare tire and wheel / mount
- Tire upgrades
- Several ramp options available
- Color options: Construction Yellow, Equipment Red, Blue, Charcoal
- Galvanizing



Other options may be available. Ask your dealer or visit our website.

\*Payload capacity is calculated by taking the GVWR and subtracting the trailer weight. Listed GVWR, weights, and dimensions are for reference only. Manufacturer reserves the right to change models and specifications as they see fit. See our web site or your local authorized dealer for more information.



towmaster.com  
**800-462-4517**  
 ©Monroe Towmaster, LLC - 0618