

Cat® D1000 GC

Diesel Generator Sets



Image shown might not reflect actual configuration.

Engine	C32
Bore – mm (in)	145 (5.7)
Stroke – mm (in)	162 (6.4)
Displacement – L (in ³)	32.1 (1959)
Compression Ratio	15.0:1
Aspiration	TA
Fuel System	EUI
Governor Type	ADEM™ A4

Model	Standby 60 Hz kW (kVA)	Emissions Performance
D1000 GC	1000 (1250)	U.S EPA Emergency Stationary Use only (Tier 2)

Standard Features

Cat® Diesel Engine

- Meets U.S. EPA Emergency Stationary Use only (Tier 2) emission standards
- Reliable performance proven in thousands of applications worldwide

Generator Set Package

- Accepts 100% block load in one step and meets NFPA 110 loading requirements
- Conforms to ISO 8528-5 G3 load acceptance requirements
- Reliability is verified through prototype testing, which includes torsional vibration, fuel consumption, oil consumption, transient performance, and endurance testing

Alternators

- Superior motor starting capability minimizes the need for oversizing the generator
- Designed to match the performance and output characteristics of Cat diesel engines

Cooling System

- Cooling systems available to operate in ambient temperatures TBD (To be validated)
- Tested to ensure proper generator set cooling

GCCP Control Panels

- User-friendly set-up and button layout for ease of use
- Multiple parameters are monitored & displayed simultaneously for full visibility
- The module can be configured to suit a wide range of applications for user flexibility

Warranty

- 24 months/1000-hour warranty for standby ratings
- 5 yrs ESC Gold Complimentary

Worldwide Product Support

- Cat dealers have over 1,800 dealer branch stores operating in 200 countries
- Your local Cat dealer provides extensive post-sale support, including maintenance and repair agreements

Financing

- Caterpillar offers an array of financial products to help you succeed through financial service excellence
- Options include loans, finance lease, operating lease, working capital, and revolving line of credit
- Contact your local Cat dealer for availability in your region

Standard and Optional Equipment

Engine

Air Cleaner

- Single element
- Dual element

Starting

- Standard batteries
- Oversized batteries
- Dual Electric Starters
- Jacket water heater

Engine Attachments

- 6" Exhaust Flexible Fittings
- 6" Exhaust Flange Kits
- Radiator Duct Flange

Alternator

Output voltage

- 480V
- 600V

Temperature Rise (over 40°C ambient)

- 125°C
- 105°C

Winding type

- Random wound

Excitation

- Internal excitation (IE)
- Permanent magnet (PM)

Attachments

- Anti-condensation heater

Power Termination

Type

- Circuit breaker (Primary)
- 1200A 1600A 2000A

- Circuit breaker (Auxiliary)

- 250A 400A

- 3-pole

- Manually operated

Trip Unit

- LSI LSIG LSIG-P

Factory Enclosure

- Sound attenuated

- Weatherproof

Attachments

- DC lighting package

Fuel Tank

- Intergrated 2100 gal (7950 L)

- Sub base 3000 gal (11356 L)

- Sub base 4200 gal (15876 L)

Control System

Controller

- GCCP 1.2

Attachments

- Remote annunciator module

- Expansion I/O module

- 100A Load Center

- 20A GFCI AC Receptacle

- Ground Fault Indication

- Audible Alarm

Charging

- Battery charger – 10A (Installed)

- Battery charger – 20A
(Shipped loose)

Cat Connect

Connectivity

- Ethernet

- Cellular

Extended Service Options

Terms

- 3 year

- 4 year

- 5 year

Coverage

- Silver

- Gold

Certifications

- UL 2200 Listed

- cUL 2200

- IBC seismic certification

Note: Some options may not be available on all models. Certifications may not be available with all model configurations. Consult factory for availability.

Package Performance – D1000 GC

Performance	Standby	
Frequency	60 Hz	
Gen set power rating with fan	1000 ekW	
Gen set power rating with fan @ 0.8 power factor	1250 kVA	
Fueling strategy	EPA ESE (Tier 2)	
Performance number	DM9933	
Fuel Consumption		
100% load with fan – L/hr (gal/hr)	272.1	(71.9)
75% load with fan – L/hr (gal/hr)	213.4	(56.4)
50% load with fan – L/hr (gal/hr)	144.7	(38.2)
25% load with fan – L/hr (gal/hr)	82.6	(21.8)
Cooling System		
Radiator air flow restriction (system) – kPa (in. water)	0.12	(0.48)
Radiator air flow – m ³ /min (cfm)	TBD	TBD
Engine coolant capacity – L (gal)	TBD	TBD
Radiator coolant capacity – L (gal)	TBD	TBD
Total coolant capacity – L (gal)	TBD	TBD
Inlet Air		
Combustion air inlet flow rate – m ³ /min (cfm)	87.6	(3094.1)
Exhaust System		
Exhaust stack gas temperature – °C (°F)	476.4	(889.5)
Exhaust gas flow rate – m ³ /min (cfm)	228.4	(8065.3)
Exhaust system backpressure (maximum allowable) – kPa (in. water)	6.7	(27.0)
Heat Rejection		
Heat rejection to jacket water – kW (Btu/min)	352	(20033)
Heat rejection to exhaust (total) – kW (Btu/min)	1024	(58206)
Heat rejection to aftercooler – kW (Btu/min)	288	(16385)
Heat rejection to atmosphere from engine – kW (Btu/min)	127	(7238)
Heat rejection from alternator – kW (Btu/min)	55	(3131)
Emissions* (Nominal)		
NOx mg/Nm ³ (g/hp-h)	2348.6	(4.93)
CO mg/Nm ³ (g/hp-h)	62.1	(0.13)
HC mg/Nm ³ (g/hp-h)	5.5	(0.01)
PM mg/Nm ³ (g/hp-h)	7.2	(0.02)
Emissions* (Potential Site Variation)		
NOx mg/Nm ³ (g/hp-h)	2841.6	(5.97)
CO mg/Nm ³ (g/hp-h)	116.1	(0.24)
HC mg/Nm ³ (g/hp-h)	10.3	(0.03)
PM mg/Nm ³ (g/hp-h)	14.1	(0.04)

*mg/Nm³ levels are corrected to 5% O₂. Contact your local Cat dealer for further information.

Weights and Dimensions

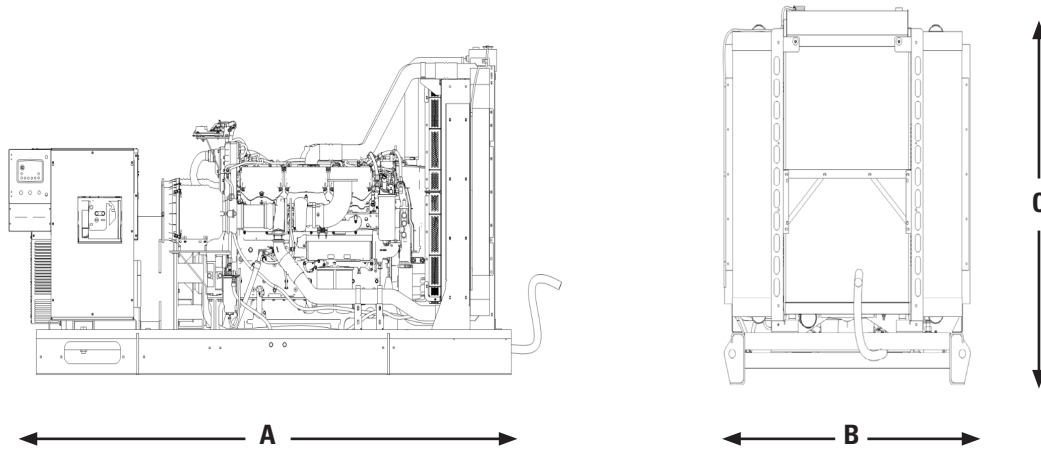

Model	Dim "A" mm (in)	Dim "B" mm (in)	Dim "C" mm (in)	Dry Weight kg (lb)
D1000 GC	4175	1856	2217.8	6654

Note: For reference only. Do not use for installation design. Contact your local Cat dealer for precise weights and dimensions.

Ratings and Definitions

Standby

Output available with varying load for the duration of the interruption of the normal source power. Average power output is 70% of the standby power rating. Typical operation is 200 hours per year, with maximum expected usage of 500 hours per year.

Applicable Codes and Standards

CSA C22.2 No. 100-14, UL 142, UL 489, UL 869A, UL 2200, IBC 2018, IEC 60034-1, ISO 3046, ISO 8528, NEMA MG1-22, NEMA MG1-33

Note: Codes may not be available in all model configurations. Please consult your local Cat dealer for availability.

Fuel Rates

Fuel rates are based on fuel oil of 35° API [16°C (60°F)] gravity having an LHV of 42,780 kJ/kg (18,390 Btu/lb) when used at 29°C (85°F) and weighing 838.9 g/liter (7.001 lbs/U.S. gal.)

LET'S DO THE WORK.™